

Sample Test 2  
Physics 132

Short Answer

1. What is the electric potential at a distance of 10 angstroms from a proton? What electric potential energy does an electron have if it is placed at that same distance?

$$V = \frac{q_p}{4\pi\epsilon_0 r} = \frac{1.6 \times 10^{-19} \text{ C}}{4\pi \cdot 8.85 \times 10^{-12} \cdot 10 \times 10^{-10} \text{ m}} = 1.44 \text{ V}$$
$$U = q_e V = -1.6 \times 10^{-19} \text{ C} \cdot 1.44 \text{ V} = -2.3 \times 10^{-19} \text{ J}$$

2. A doubly charged ion is accelerated from rest through a potential difference of 100 MV. What is its energy after the acceleration?

$$\begin{aligned}\Delta U &= q\Delta V \\ &= (+2e) \cdot (100 \text{ MV}) \\ &= 200 \text{ MeV}\end{aligned}$$

3. Consider an electric dipole. Where is the potential zero and why?

The potential is zero everywhere on a plane that is perpendicular to the dipole and lies halfway between the positive and negative charge. The potential is zero there because there are equal and opposite contributions from the positive and negative charges.

4. What area is required to make a 1 milliFarad capacitor. Assume parallel plates separated by a distance of 0.1 mm and a dielectric with  $k=3$ .

$$C = \frac{\kappa\epsilon_0 A}{d}$$
$$A = \frac{C d}{\kappa\epsilon_0} = \frac{1 \times 10^{-3} \text{ F} \cdot 0.1 \times 10^{-3} \text{ m}}{3 \cdot 8.85 \times 10^{-12}} = 3.77 \times 10^3 \text{ m}^2$$

5. Explain briefly how a dielectric works to lower the capacitance of a capacitor. You may wish to use the definition of capacitance and how the potential is related to the electric field to do this. Assume parallel plates.

The dielectric develops a charge separation. This lowers the field between the plates for the same charge on the plates. The lowered field leads to a lowered voltages. Thus the capacitance rises--same charge but lower voltage.

6. You have three 10mF capacitors. What is the maximum capacitance you can create with them and how do you do this? What is the minimum capacitance you can create with them and how do you do this?

Maximum capacitance: Three in parallel  $C = C_1 + C_2 + C_3 = 30mF$

Minimum capacitance: Three in series  $\frac{1}{C} = \frac{1}{C_1} + \frac{1}{C_2} + \frac{1}{C_3} \Rightarrow C = \frac{10}{3}mF$

7. Four protons are arranged at the corners of a square with side 1 angstrom. What is the total stored energy?

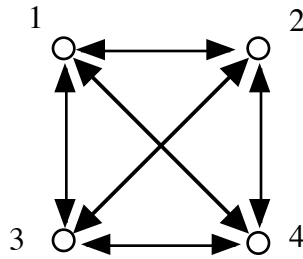

$$U = \frac{q_1 q_2}{4\pi\epsilon_0 r_{12}} + \frac{q_1 q_3}{4\pi\epsilon_0 r_{13}} + \frac{q_1 q_4}{4\pi\epsilon_0 r_{14}} + \frac{q_2 q_3}{4\pi\epsilon_0 r_{23}} + \frac{q_2 q_4}{4\pi\epsilon_0 r_{24}} + \frac{q_3 q_4}{4\pi\epsilon_0 r_{34}}$$

We sum over the energies pairwise.

8. Two 10 mF capacitors are in series. These caps are in parallel with a single 20 mF capacitor. Draw the circuit, compute the equivalent capacitance. If this array of capacitors is hooked up to a 12V battery, what is the charge on each capacitor?

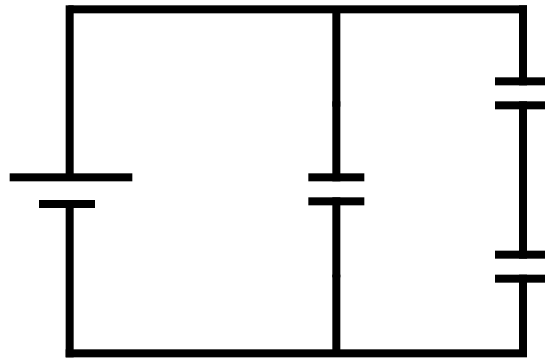

$$\frac{1}{C_{series}} = \frac{1}{C_{10}} + \frac{1}{C_{10}} \Rightarrow C_{series} = 5mF$$

$$C_{eq} = C_{series} + C_{20} = 25mF$$

The charge on the 20 mF can be calculated directly, since we know that the voltage across it is 12V.

$$q_{20} = C_{20}V = 20mF \cdot 12V = 240mC$$

We can calculate the charge on each of the capacitors in series by finding the charge on the equivalent capacitor. The charge on each capacitor in series is equal to the charge on the equivalent capacitor.

$$q_{eq} = C_{eq}V = 5mF \cdot 12V = 60mC$$

9. A 1F capacitor is charged to 100V. How much energy is stored in this capacitor? What is the charge stored on this capacitor?

$$q = CV = 1F \cdot 100V = 100C$$

$$U = \frac{1}{2}CV^2 = \frac{1}{2}(1F)(100V)^2 = 5000J$$

11. Consider a 100 m length of copper wire that has a radius of 1mm. What is its resistance? If it is connected to a 10V ideal battery, compute the current and the power.

$$R = \rho \frac{L}{A} = 1.69 \times 10^{-8} \Omega m \cdot \frac{100m}{\pi \cdot (1 \times 10^{-3}m)^2} = 0.54 \Omega$$

$$i = \frac{V}{R} = 18.52A$$

$$P = i^2R = (18.52A)^2 \cdot 0.54 \Omega = 185.2W$$

12. A beam of protons has a bunch with  $10^{31}$  particles. The length of the beam is 100 m and the diameter is 1 micron. The proton speed is 0.99 c. What is the charge density in the beam? What is the current density? What is the current?

$$\rho = \frac{10^{31} \cdot 1.6 \times 10^{-19}}{100m \cdot \pi \cdot (0.5 \times 10^{-6})^2} = 2.04 \times 10^{22} C / m^3$$

$$j = nqv$$

$$= \frac{10^{31}}{100m \cdot \pi \cdot (0.5 \times 10^{-6})^2} \cdot 1.6 \times 10^{-19} \cdot (0.99 \cdot 3 \times 10^8 m / s) = 6.05 \times 10^{30} A / m^2$$

$$i = j \cdot A = j \cdot \pi \cdot (0.5 \times 10^{-6})^2 = 4.75 \times 10^{18} Amp!!$$

13. A 100 ohm resistor is connected to a 10 volt power supply. Compute what the current is if the power supply is an ideal battery.

$$i = \frac{\varepsilon}{R} = \frac{10V}{100\Omega} = 0.1A$$

14. An electric potential is given below. What is the electric field?

$$V = 5x^3 + 2xy$$

$$E_x = -\frac{\partial V}{\partial x} = -15x^2 - 2y$$

$$E_y = -\frac{\partial V}{\partial y} = -2x$$

15. An electric field is given below. Assuming that the potential is zero at the origin, what is the electric potential at a point  $(x, y)$

$$\begin{aligned}\vec{E} &= -x\hat{i} - y\hat{j} \\ V &= - \int_{(0,0)}^{x,y} \vec{E} \cdot d\vec{r} = - \int_{(0,0)}^{x,y} (-x\hat{i} - y\hat{j}) \cdot (dx\hat{i} + dy\hat{j}) \\ &= \int_{(0,0)}^{x,y} (x dx + y dy) \\ &= \frac{x^2}{2} + \frac{y^2}{2}\end{aligned}$$

Problems.

1. Consider a ring of charge that has an inner radius  $a$  and an outer radius  $b$ . It has a charge density  $\sigma$

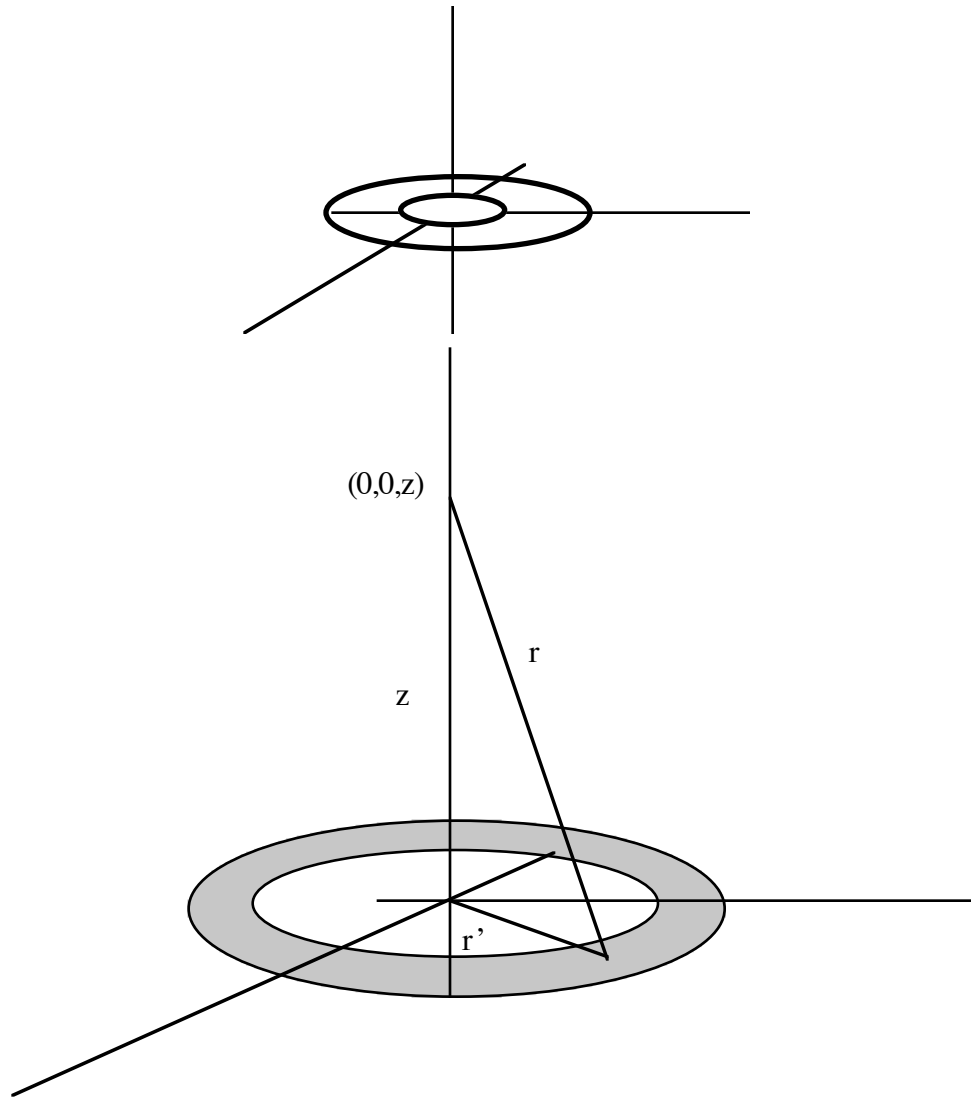

a) Derive an expression for the potential along its axis.

$$\begin{aligned}
 V &= \int \frac{dq}{4\pi\epsilon_0 r} \\
 dq &= \sigma r' d\theta dr' \\
 r &= \sqrt{r'^2 + z^2} \\
 V &= \int_{a,0}^{b,2\pi} \frac{\sigma r' d\theta dr'}{4\pi\epsilon_0 \sqrt{r'^2 + z^2}} = 2\pi \cdot \frac{\sigma}{4\pi\epsilon_0} \cdot \int_a^b \frac{r' dr'}{\sqrt{r'^2 + z^2}} \\
 &= \frac{\sigma}{2\epsilon_0} \left[ \sqrt{r'^2 + z^2} \right]_a^b \\
 &= \frac{\sigma}{2\epsilon_0} (\sqrt{b^2 + z^2} - \sqrt{a^2 + z^2})
 \end{aligned}$$

2. Consider the charged rod below. Assume that it is uniformly charged with charge per unit length  $\lambda$ .

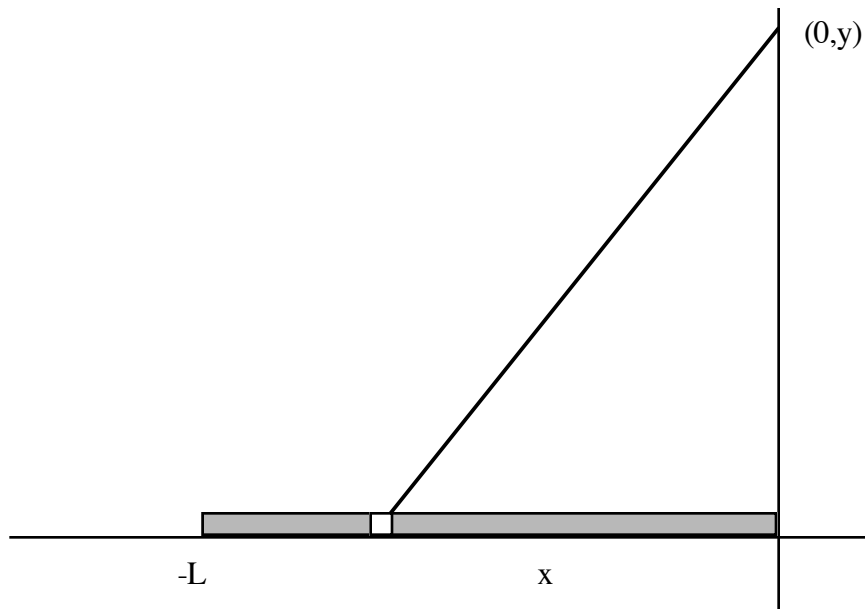

a) Write an expression for the electric potential due to a small charge  $dq$  at the point p?

$$dV = \frac{dq}{4\pi\epsilon_0 r} = \frac{dq}{4\pi\epsilon_0 \sqrt{x^2 + y^2}}$$

b) Write an expression for the  $dq$  and the  $r$  in terms of  $x$  and the distance  $y$ .

$$\begin{aligned}
 dq &= \lambda dx \\
 r &= \sqrt{x^2 + y^2}
 \end{aligned}$$

c) What is the potential at the point indicated? You may need the integral

$$\int_{-L}^0 \frac{dx}{\sqrt{x^2 + y^2}} = \ln[y] - \ln[-L + \sqrt{L^2 + y^2}]$$

$$\begin{aligned} V &= \int_{-L}^0 \frac{\lambda dx}{4\pi\epsilon_0 \sqrt{x^2 + y^2}} = \frac{\lambda}{4\pi\epsilon_0} \int_{-L}^0 \frac{dx}{\sqrt{x^2 + y^2}} \\ &= \frac{\lambda}{4\pi\epsilon_0} \cdot (\ln[y] - \ln[-L + \sqrt{L^2 + y^2}]) \\ &= \frac{\lambda}{4\pi\epsilon_0} \ln \frac{y}{-L + \sqrt{L^2 + y^2}} \end{aligned}$$

3. Consider the circuit shown below. Assume all capacitors are 1 mF and the battery is 10 V

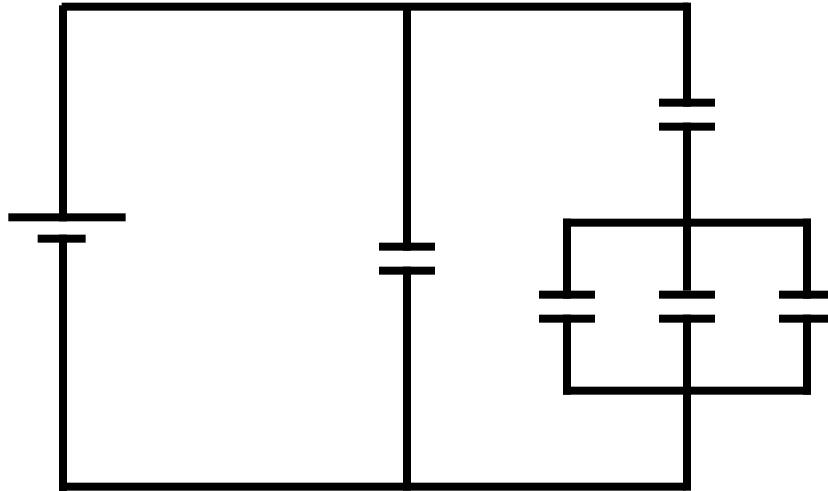

a) What is the equivalent capacitance.

$$C_{3p} = C + C + C = 3mF$$

$$\frac{1}{C_s} = \frac{1}{C_{3p}} + \frac{1}{C} \Rightarrow C_s = \frac{3}{4}mF$$

$$C_{eq} = C_s + C = \frac{7}{4}mF$$

b) What is the charge on each capacitor?

The charge on the left capacitor is the easiest.

$$q_L = CV = 1mF \cdot 10V = 10mC$$

Now compute the charge on the equivalent capacitance for the array of charges on the right.

$$q = C_{series} V = \frac{3}{4}mF \cdot 10V = \frac{30}{4}mC$$

The charge on this equivalent capacitor is the same as the charge on the series capacitors that were used to create it. So the charge on the upper right capacitor has this value. We are left with the three capacitors in parallel. The voltage across the three is the same as the voltage across the equivalent capacitor. We can calculate this voltage, since we know the charge on the equivalent capacitor--it is the charge we just computed.

$$V = \frac{q}{C_{3p}} = \frac{30/4 mC}{3mF} = 2.5V$$

Now that we know the voltage across each of these capacitors, we can find the charge on each.

$$q = CV = 1mF \cdot 2.5V = 2.5mC$$

We repeat this for each capacitor in parallel, but in this case, they are all the same...

c) If all of the capacitors were 10 Ohm resistors instead, what would the equivalent resistance be and how much current would flow through it?

This actually belongs on the next test. The solution is:

$$\frac{1}{R_{3p}} = \frac{1}{R} + \frac{1}{R} + \frac{1}{R} \Rightarrow R_{3p} = \frac{R}{3} = \frac{10}{3} \Omega$$

$$R_s = R_{3p} + R = \frac{40}{3} \Omega$$

$$\frac{1}{R_{eq}} = \frac{1}{R_s} + \frac{1}{R} = \frac{3}{40} + \frac{1}{10} \Rightarrow R_{eq} = \frac{40}{7} \Omega$$

$$i = \frac{V}{R_{eq}} = \frac{10V}{40/7} = \frac{7}{4} \text{ Amperes}$$